



SLIMWALL 35 CURTAIN WALL

SlimWall 35 is a slender aluminum curtain wall system designed for projects that prioritize minimal sightlines and refined architectural expression.

Developed as a stick façade system, it enables clean, transparent façades while maintaining structural integrity and long-term performance. Its proportions support a lightweight visual appearance, making it well suited for designs that emphasize openness and simplicity.

Designed for structures up to two floors, SlimWall 35 combines minimal aesthetics with Passive House certified performance, supporting energy-efficient façade solutions in residential and low-rise commercial applications.

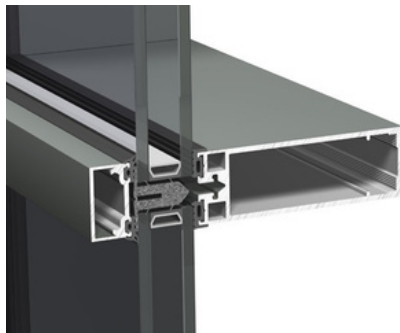

- MADE IN CANADA
- HIGH PERFORMANCE ALUMINUM SYSTEMS FROM REYNAERS
- SOBINCO ACCESORIES

nordicaaluminum.com
sales@open-windows.ca - 604-971-6736

PERFORMANCE HIGHLIGHTS

- **Passive House Certified System:** Designed to meet Passive House performance standards for energy-efficient façade applications 
- **Slender Façade Profiles:** Minimal sightlines enhance transparency and reduce visual weight in façade design
- **Lightweight Structural Design:** Engineered for applications up to two floors, supporting low-rise construction
- **Glass Capacity:** Supports glazing weights up to 992 lbs, enabling large glass surfaces
- **Design Flexibility:** Supports a range of façade configurations for clean and consistent architectural integration

NORDICA
aluminum

A division of  open windows